

Description:

ENH-VB200386-02 is a VA high contrast LCD,white on black,Transmissive LCD,working voltage is 3.3 V,12 O'clock viewing angle,HT1621 controller,very popular applied for Industrial control,home-appliance,medicial application.Shenzhen Enrich Electronics Co.,Ltd warmly welcome your factory tour.

Specification:

1.Product name :	ENH-VB200386-02
2.Board Size:	87.0x53.50mm
3.LCD size :	69.0x48.50mm
4.Viewing area :	66.0x45.50mm
5.Resolution:	7 Segment LCD
6.Display type :	VA/Transmissive/Negative
7.Viewing angle:	12 O'clock
8.Drive method :	1/4 duty, 1/3 bias
9.Working temp :	0℃~+50℃
10.Storage temp :	-10℃~+60℃
11.Connector:	COB
12.Drive IC :	HT1621
13.Backlight :	White led backlight
14.Interface:	SPI/Serial/Parallel
15.Working Voltage:	3.3V

Detail images:

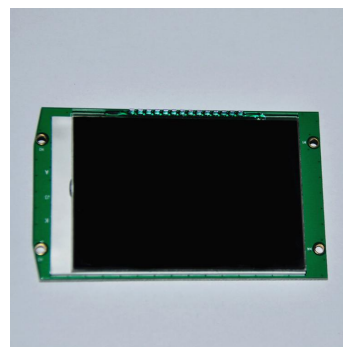
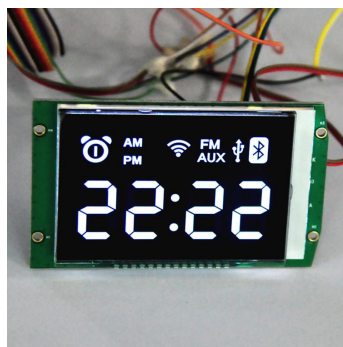
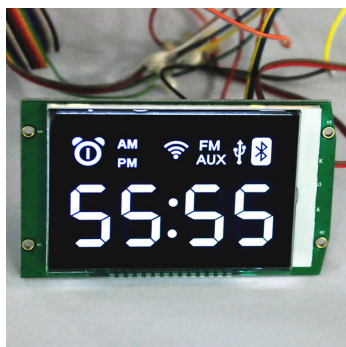

Display drawing:

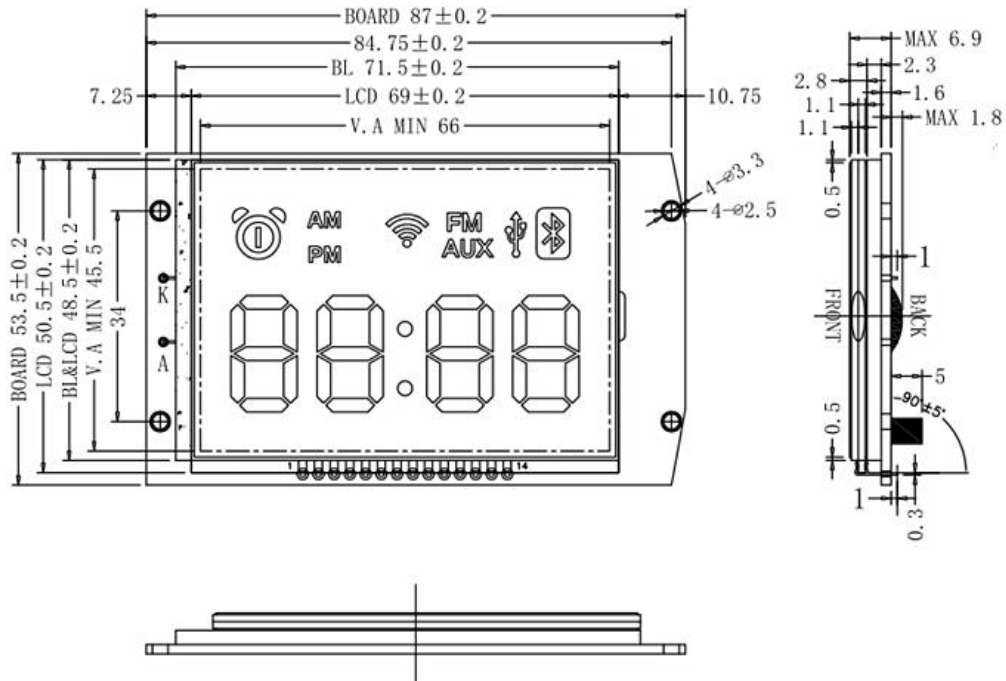

PIN	1	2	3	4	5	6	7	8	9	10	11	12	13	14
COM1	COM1				1A	2A	COL	3A	4A	Q2	T1			
COM2		COM2		1F	1B	2F	2B	3F	3B	4F	4B	AUX	AM	
COM3			COM3	1G	1C	2G	2C	3G	3C	4G	4C	FM	PM	
COM4				COM4	1E	1D	2E	2D	3E	3D	4E	4D	Q1	T2

Customer's Application:



LCD for Industrial Device

FAQ:

1.Q:What is the MOQ ?

A: 5-100 pcs for our own available designs

2.Q:Can I get samples?

A:Yes,just give us sample orders,and free samples for custom

3.Q:How to customize an lcd module?

A:Give us messages to design lcd modules and confirm the drawings

4.Q:Can mould cost been returned ?

A:Yes, if quantity satisfied.

Contact us:



Shenzhen Enrich Electronics Co.,Ltd



Cassie Huang

[Tel:+86-755-27864416](tel:+86-755-27864416)

Fax:+86-755-27864653

Mobile: +86 159 8936 6182

Email: cassie@rxdisplay.com

Wechat: 18296551775

Whatsapp: + 86 182 9655 1775

Skype:live:cassie_1191